

I

© Aprimatic S.p.A., 1999. Tutti i diritti riservati.

Nessuna parte di questo documento può essere copiata o tradotta in altre lingue o formati senza il consenso scritto di Aprimatic S.p.A.

Le specifiche del prodotto sono soggette a modifiche senza preavviso. Pertanto il presente documento potrebbe non corrispondere esattamente alle caratteristiche del prodotto.

Licenze e marchi

Il logotipo "Aprimatic" è un marchio registrato di Aprimatic S.p.A.

Cod. A1514000

Stampato in Italia

GB

© Aprimatic S.p.A., 1999. All rights reserved.

No part of this document may be reproduced or translated into any other language or form without the written permission of Aprimatic S.p.A.

The product specifications may be modified without prior notice. Therefore this document may not correspond exactly to the characteristics of the product.

Licences and trademarks

The "Aprimatic" logo is a trademark registered by Aprimatic S.p.A.

Code A1514000

Printed in Italy

F

© Aprimatic S.p.A., 1999. Tous droits réservés.

Aucune partie du présent document ne peut être dupliquée ou traduite dans d'autres langues sans l'autorisation écrite d'Aprimatic S.p.A.

Les caractéristiques du produit peuvent être soumises à modifications sans préavis. Le présent document peut de ce fait ne pas correspondre exactement aux caractéristiques du produit.

Licences et marques

Le logotype «Aprimatic» est une marque déposée d'Aprimatic S.p.A.

Réf. A1514000

Imprimé en Italie

D

© Aprimatic S.p.A., 1999. Alle Rechte vorbehalten.

Jede Vervielfältigung oder Übersetzung in andere Sprachen bzw. Formate, auch auszugsweise, muß von Aprimatic S.p.A. schriftlich genehmigt werden.

Änderungen ohne Vorankündigung vorbehalten. Es sind daher Abweichungen zwischen den hier angegebenen Daten und den Daten des Produkts möglich.

Lizenzen und Warenzeichen

Das Logo „Aprimatic“ ist ein eingetragenes Warenzeichen der Aprimatic S.p.A.

Code A1514000

Gedruckt in Italien

E

© Aprimatic S.p.A., 1999. Todos los derechos reservados.

Queda prohibido copiar o traducir a otros idiomas o formatos cualquier parte de este documento sin la autorización escrita de Aprimatic S.p.A.

Las características técnicas del producto pueden modificarse sin previo aviso; por consiguiente el presente documento podría no corresponder exactamente a las características del producto.

Patentes y marcas

El logotipo «Aprimatic» es una marca registrada de Aprimatic S.p.A.

Cód. A1514000

Impreso en Italia

Safety recommendations

- The manufacturer's instructions must be strictly observed.
- The installer must check the installation and the correct functioning of the device.
- The product must not be used incorrectly or for purposes that are not envisaged.
- The product must not be tampered with or modified in any way.
- Always use original spare parts.
- Cordon off the working area to prevent the access of unauthorised persons.
- Ensure that the working area is clear of obstacles and the floor is not slippery.
- All equipment used must be in good working condition.
- The working area must be sufficiently well lit and free of health hazards.
- Unauthorised persons must not enter the working area.
- The working area must not be left unattended.

Purpose of the manual

This manual was drawn up by the manufacturer and is an integral part of the product. The information it contains is addressed to expert operators that carry out the installation and extraordinary maintenance. They must have the specific qualifications and training to carry out the operations assigned to them correctly and under the maximum safety conditions. Strict observation of the instructions contained in the manual will ensure safety, optimum operation and prolonged functioning of the product. To avoid incorrect manoeuvres and the consequent risk of accidents, it is important to read this manual carefully, strictly observing the instructions given.

Application range

Device for Aprimatic operators for swing gates.

Contents

1. DESCRIPTION	5
1.1 Block diagram of the device	5
2. INSTALLATION	5
2.1 Preparation	5
2.2 Assembly	5
2.3 Electrical connections	5
3. STARTING UP	6
3.1 Functioning tests	6
3.2 Trimmer adjustment	6
3.3 Functioning programming	6
4. FUNCTIONING CONTROL	6
4.1 Checking the functioning of external devices	6

The logo for Aprimatic, featuring the brand name in a bold, sans-serif font with a registered trademark symbol. Below the text is a horizontal line with several vertical bars of varying heights underneath it.

Aprimatic S.p.A. • Zona Industriale Fossatone
40060 Villa Fontana • Medicina • Bologna (ITALY)
tel. +39-051.6979511 • fax +39-051.6930396

1. DESCRIPTION

Device fitted with Aprimatic microprocessor designed to drive 2 motors with a maximum power of 380 Watt. Stand-by consumption 15 Watt.

1.1 BLOCK DIAGRAM OF THE DEVICE

- TR1 Pause time trimmer
- TR2 Gate closing delay trimmer
- TR3 Thrust force adjustment trimmer
- JP **Note** - Turn clockwise to decrease sensitivity and increase thrust force.
Set of jumpers



- | | |
|-----------------------------------|------------------------|
| JP1 Semiautomatic mode | Automatic |
| JP2 Reverse stroke disabled | Enabled |
| JP3 Pre-flashing disabled | Enabled |
| JP4 External wing motors (Pronto) | Recessed motors (EM73) |
| JP5 2 motors (2 wings) | 1 motor (1 wing) - M1 |

Note - The wing opening delay is fixed at 1.5 seconds.

- CN1 Plug-in Aprimatic radio receiver terminal board
- CN2 Input terminal board
- CN3 Power supply and transformer terminal board
- CN4 Accessories terminal board
- FS1-FS9 Faston plug connectors
- C.B. Terminal for battery-charger circuit connection
- M1 Terminal for motor connection 1 (wing 1)
- M2 Terminal for motor connection 2 (wing 2)

2. INSTALLATION

- CAUTION** - The product must only be installed by qualified servicing and/or installation personnel.
- CAUTION** - The electrical system must comply with current regulations in the country where the product is installed.
- CAUTION** - Always make sure that the mains power supply is turned OFF before opening the container. Ensure that there is a good earthing system. Always connect it to the relative terminals.

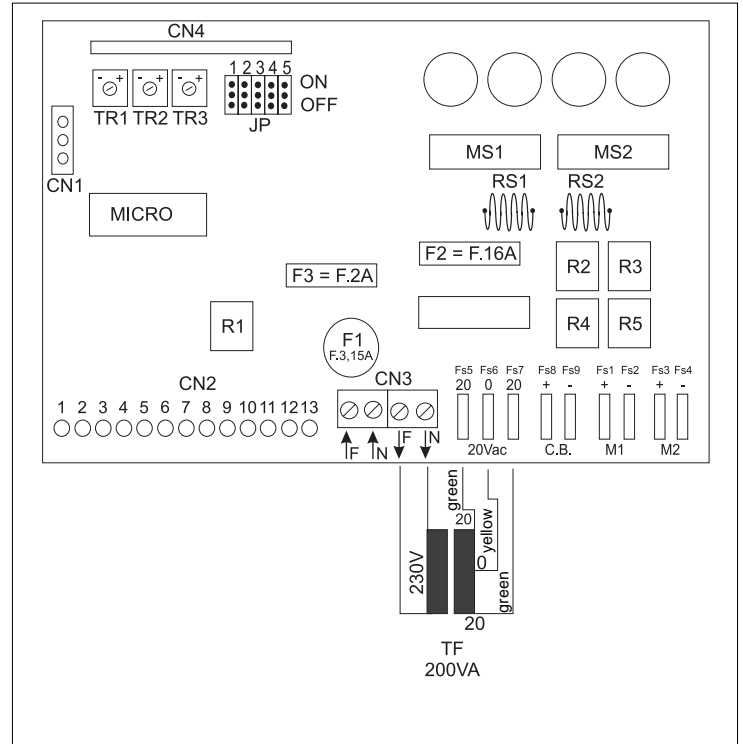

2.1 PREPARATION

Before installing the device, prepare the tools required for securing it to the wall and to make the electrical connections. The following are also required:

1. expansion wall plugs dia. 6 mm
2. Skintop type PG16 cable clamps
3. a multipole switch with a minimum contact opening of 3 mm for mains power supply
4. an emergency pushbutton
5. approved cables for external use with minimum cross-section of 0.75 and 1.5 mm²

2.2 ASSEMBLY

It is not necessary to drill any holes inside the plastic container to fit the device.

1. Secure the device at a minimum height of 30 cm, using the securing holes on the 4 corners of the plastic container.
2. Insert the connecting cables, through the holes in the bottom of the container and the cable clamps indicated.
3. Fit a multipole switch for the power supply upstream of the device.
4. Fit an emergency pushbutton in a position where the automation system can be seen and so that the power supply to the system can be completely cut-off.
5. Use 1.5 mm² section cables for the motor power supply and 0.75 mm² section cables for 24 VDC devices.

Note - The safety contacts (terminals 2-4 stop input, 2-3 photocell input, 2-6 internal or additional photocell input) if not used, must be jumpered by the installer.

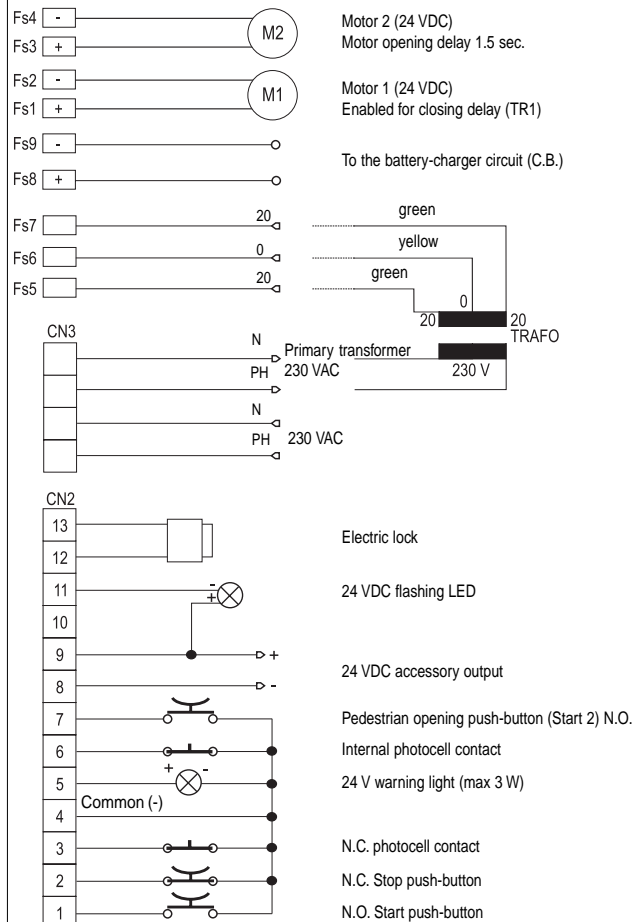

2.3 ELECTRICAL CONNECTIONS

CAUTION - The electrical system must comply with standards in the country where it is installed. The system must only be installed by skilled personnel. Use approved material.

CAUTION - Make sure that the mains power supply is turned OFF before making the connections.

CAUTION - Do not use intercom or telephone cables.

CAUTION - Carefully strap the low voltage cable near the terminal board CN2.

- Carefully strap the power supply cable near the terminal board CN3.

NOTE – Terminal boards CN1 and CN2 are dedicated **exclusively** to plug-in cards produced by Aprimatic. It is not possible to connect cable and/or cards with a different format and/or manufacturer.

Make the electrical connections as indicated in the diagram shown above.

3. STARTING UP

After completing the connections as indicated and checking the electrical connections carefully, turn ON the mains power supply and check that the system is functioning correctly, as explained below.

3.1 FUNCTIONING TESTS

When all the connections have been made, it is necessary to check the automation system, checking that the automation opens when you press the start push-button. If it closes, invert the motor connections.

3.2 TRIMMER ADJUSTMENT

The T4Power device has 3 adjustment trimmers and 3 jumpers for selecting the functions and times.

Trimmer TR1 – This trimmer is used to adjust the pause time before automatic closing of the gate. The adjustment range of the pause time is from 5 to 180 seconds.

Trimmer TR2 – This trimmer is used to adjust the gate closing delay for motor 1. The adjustment range is from 0 to 15 seconds.

Trimmer TR3 – This trimmer is used to adjust the thrust force of the operators to match the gate structure and adjusts the sensitivity of the safety auto-reverse (decrease sensitivity = more thrust; increase sensitivity = less thrust). See JP4.

NOTE – These settings are learned immediately by the microprocessor also while the device is operating.

4 FUNCTIONING CONTROL

After selecting the functioning mode and times, check the external devices connected to the card.

4.1 CHECKING THE FUNCTIONING OF EXTERNAL DEVICES

Start input - N.O. type contact which supplies the start pulse to the automation.

Stop input – N.C. safety contact which has priority in all states and functions. If the stop input is given, the device stops the gate immediately and it only starts up again when the start push-button is pressed: this closes the gate. When the stop input is given, the device ignores all the commands.

Photocell input – N.C. safety contact which is only enabled during closing. If the photocell is triggered, the automation stops for 1 second and the gates then re-open until the work time expires. When the gate is open and the photocells are triggered, the photocells block gate closing.

Pedestrian start input – N.O. safety contact. Use the push-button connected to this input to open one wing only (pedestrian opening). If a start pulse is given, both wings are opened, as the start signal has priority over the pedestrian start input. The pedestrian start is ignored if the device has been commanded with a start pulse and when it is moving.

Opening safety input – N.C. safety contact. An input which is enabled during opening or closing. When the input is enabled, the gates stop immediately. When the input is disabled, the gates start to move in the same direction as before, after a pause of 1 second.

Electric lock output – 12VAC output with maximum load of 15W, which commands the electric lock for approximately 2 sec. during opening.

Warning light output – 24VDC output with maximum load of 3W, which commands the gate state warning light. Light OFF: gate closed. Steady light: gate open or opening. Flashing light: gate closing.

3.3 FUNCTIONING PROGRAMMING

It is now possible to program the device.

CAUTION – Every time you program the device, disconnect the electrical power supply to cancel the previously set program.

For the settings of the jumper set JP, see 1.1 “Block diagram of the device” - “Set of jumpers”.

AUTOMATIC MODE – When you select automatic functioning and a start pulse is given, the device commands opening until the end of the work time, the gate stays open for the pause time selected and then closes automatically.

- If a pulse is given during opening, the control system ignores it and the gate continues its opening movement.
- If a pulse is given or the photocells are triggered during closing, the gate changes direction and starts to open.
- If the photocells are triggered during the pause time, the device remains in pause until the photocells are cleared.

SEMIAUTOMATIC MODE WITH STOP – When you select semiautomatic functioning when the gate is closed and a start pulse is given, the device commands gate opening until the end of the work time set. If another start pulse is given during opening, the gates stop in position until another start pulse is given, which commands closing. A start pulse given during closing commands re-opening of the gates.

NOTE – In both functioning modes, the motor power supply is cut off by the electronic control of the current absorption. This occurs when the gates reach the mechanical limit switch, during opening and closing, or when they come into contact with an obstacle.

Flashing light output - 24 V output which commands the flashing light.

This output commands the flashing light with a pulsating power supply with frequency of 1 Hz: the light is ON for 0.5 seconds and OFF for 0.5 sec. If pre-flashing is enabled, this output is enabled 3 seconds before the command to move the gates (opening and closing).

NOTE - Only use Aprimatic ET Series 24V LED flashing lights to avoid a fault with the output which will cause incorrect functioning of the entire system.

Motor output – The T4Power device has two outputs for independent motors. The output for motor 1 is the one used to signal the gate closing delay by selecting the relative trimmer. The output for motor 2, on the other hand, has a fixed opening delay of 1.5 seconds. If the pedestrian start is used (one-wing opening), only the gate connected to the output for motor 1 will start.

NOTE – If this device is used in gates with only one wing, the motor must be connected to the output for motor 1.

Battery-charger circuit connection (*not supplied*) – The T4Power device can be connected to an auxiliary circuit for controlling an emergency battery unit which can be used, in the event of a power failure, for emergency purposes (opening/closing). This circuit, which must be fitted in the same plastic container which houses the T4Power device, must be connected to the C.B. terminal **respecting the polarity indicated**. The battery unit is contained in a separate container and is not supplied with the device.

NOTE – Only use the emergency battery unit supplied by Aprimatic.